

INSTRUCTIONS for ASSEMBLING DATASAFE[®] HX UBC BATTERY RACKS

Read all instructions carefully and observe all warnings before installation.

See *Installation, Operation and Maintenance Manual* for battery information.

1. GENERAL INFORMATION

- DataSafe[®] HX UBC battery racks are available in 1 Tier through 5 Tier configurations. Rack lengths are determined by a pre-set number of battery blocs per tier.

Number of battery blocs per tier:

6HX800: 4, 5, 6, or 10
12HX205*: 8, 10, 12 or 20
12HX300: 4, 5, 6 or 10
12HX330: 4, 5, 6 or 10
12HX400: 4, 5, 6 or 10
12HX500, 505, 540: 4, 5, 6 or 10
16HX500F: 4, 5 or 6
16HX800F, 925F: 4, 5 or 6

* The 12HX205 battery rack is a 2 Row per Tier design.

- Racks are available in non-seismic and seismic versions. The seismic versions have been qualified to UBC Zone 4 Essential, for at or below grade installations.
- Racks are supplied unassembled. The components consist of: corner frames, cross braces, shelves, top cover, assembly hardware and retainers (seismic racks only).
- This manual covers the assembly of the front terminal 16HX and top terminal 6HX and 12HX rack models separately. For PowerSafe[®] VE battery models, use the 12HX section.

2. SAFETY PRECAUTIONS

- Assemble racks in accordance with the instructions contained in this document without deviations.
- Refer to UBC, OSHA, and EPA regulations and local ordinances that pertain to battery installation and storage.
- Refer to additional safety precautions contained in the DataSafe[®] HX *Installation, Operation and Maintenance Manual*.
- For installations where grounding is required for NEC and/or local codes, refer to the section on rack grounding in this manual.

3. SERVICE INFORMATION

- Should you require installation supervision, service, parts, accessories or maintenance, EnerSys[®] has a service organization to assist with your new rack purchase. Contact your nearest EnerSys office or call the corporate number listed on the back of this manual and ask for EnerSys Reserve Power Service.

4. INSPECTION OF BATTERY RACK COMPONENTS

- Upon receipt, check each package against the packing list to ensure all components and quantities are correct.

- Inspect for visual damage while the carrier representative is still on-site. Make note of any damage.
- **If any part has not been received or has been damaged, DO NOT proceed with installation until all parts are available.**

5. INSTALLATION CONSIDERATIONS

If you have any questions concerning the following installation considerations, contact your EnerSys® sales representative.

- Consider available floor space, including aisles for cell installation, maintenance, and possible cell replacement.
- Aisle spacing should be in accordance with the NEC. **ALL OTHER APPLICABLE CODE REQUIREMENTS SHOULD ALSO BE CONSIDERED.**
- Minimum clearance between seismic racks and any objects (including walls, equipment and other racks) is recommended to be 4 in. (100 mm). **NO SEISMIC RACKS SHOULD BE BUTTED TOGETHER, END-TO-END OR BACK-TO-BACK.**
- If Inter-rack cable connectors are provided by EnerSys, they are based on a rack spacing of 4 in. (100 mm); any length over this is the responsibility of the purchaser.
- The floor/mounting platform must be reasonably level. Shimming up to 0.25 in. (6 mm) maximum may be used to have cell support rails level both front-to-back and side-to-side. Shimms and shimming hardware are user supplied.

- The floor/mounting platform must be capable of supporting the weight of the battery and rack system, as well as any auxiliary equipment. **ALL APPLICABLE CODE REQUIREMENTS SHOULD BE CONSIDERED.**
- **FLOOR ANCHORING AND ITS DESIGN ARE THE RESPONSIBILITY OF THE PURCHASER.** Anchoring should meet all local, state and federal codes and industry standards.

6. INSTALLATION EQUIPMENT AND SUPPLIES

Before working with the battery system, ensure that you have the tools and equipment listed below.

- Chalk line
- Concrete drill (for floor anchors)
- Floor shims (user-supplied)
- Level
- Ohmmeter (for ground testing)
- Open end/box wrenches (SAE dimensions)
- Ratchet set w/ sockets (SAE dimensions)
- Square
- Tape measure
- Torque wrench (10-100 ft-lb.)

Table 1 – Torque Specifications

Bolt Size	Torque	
	ft-lb.	Nm
½-13	50	68

7. DATASAFE® 16HX UBC BATTERY RACK ASSEMBLY

7.1 DATASAFE® 16HX UBC BATTERY RACK FLOOR ANCHORING

FLOOR ANCHORING AND ITS DESIGN ARE THE RESPONSIBILITY OF THE PURCHASER. Contact your EnerSys® sales representative if you have any questions.

- Refer to the rack assembly drawing for corner frame and anchor bolt layout. Each rack requires 4 anchor bolts.
- Anchoring holes are 0.56 in. (14.2 mm) diameter.
- Mark locations for anchor bolts. It may be helpful to assemble the corner frames, bottom shelf and top cover to use as a template to mark the locations of the anchor bolts. See Figure 7.1 and Sections 7.2, 7.3 and 7.4 for assembly instructions.

CAUTION: The partial rack assembly will have to be moved to install the anchors, use appropriate lifting equipment to avoid injury.

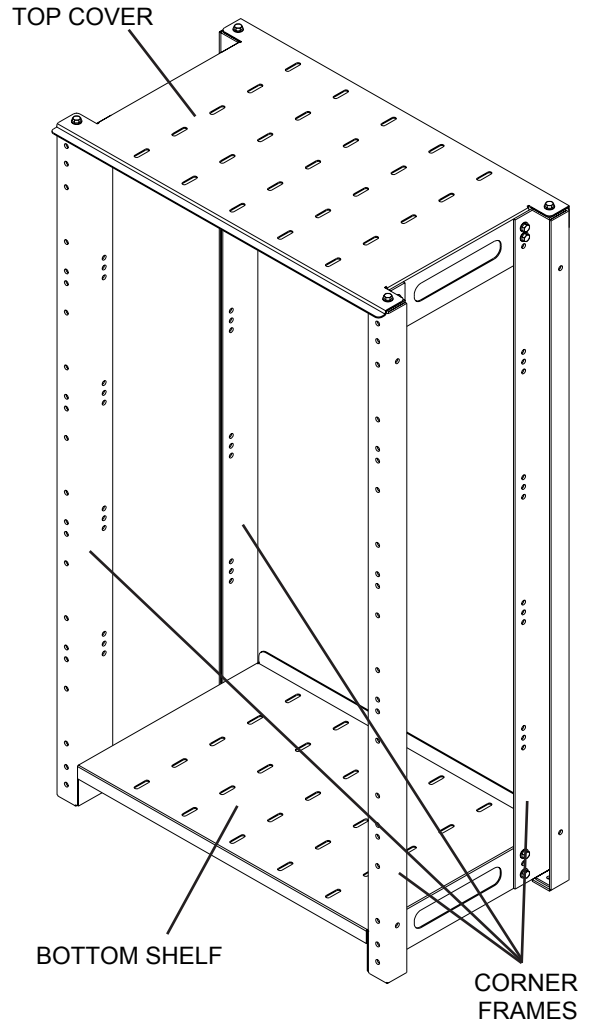

Figure 7.1

- Install anchor bolts as indicated by the manufacturer's instructions.

7.2 DATASAFE® 16HX UBC BATTERY RACK BOLTED CONNECTIONS

All bolted connections will be made with ½-13 x 1.75" Hex Bolts and associated hardware. Torque bolted connections per Table 1.

- Bolted connections should be assembled per Figure 7.2.

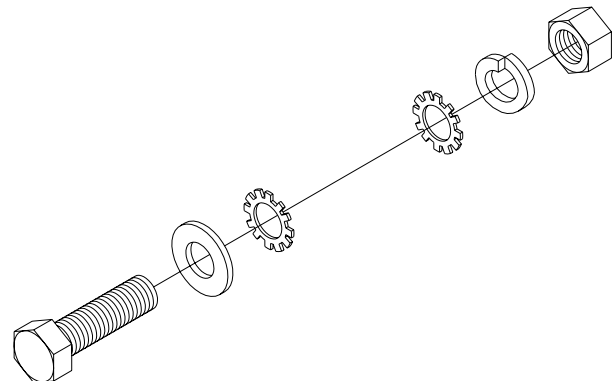

Figure 7.2

7.3 DATASAFE® 16HX UBC BATTERY RACK SEISMIC SHELF PREPARATION

Seismic racks require neoprene strips to be installed on the shelves and top cover. Install the self-adhesive strips per the following:

- Top Cover: inside bottom of flanges, see Figure 7.3a.
- Shelf: inside bottom of flanges and back lip of shelf, see Figure 7.3b.
- Bottom Shelf: back lip of shelf, see Figure 7.3c.
- Non-seismic racks do not require the neoprene strips.

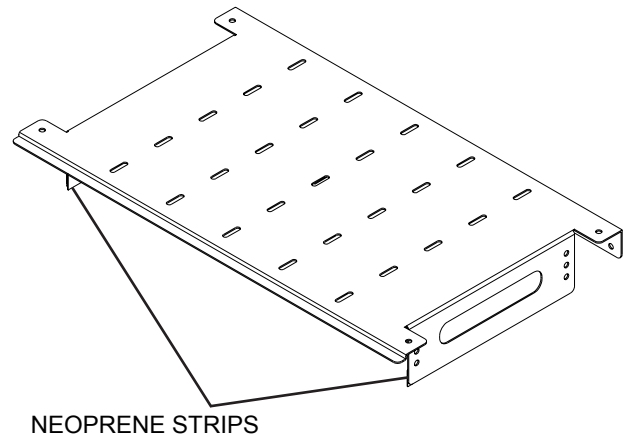

Figure 7.3a – Top Cover

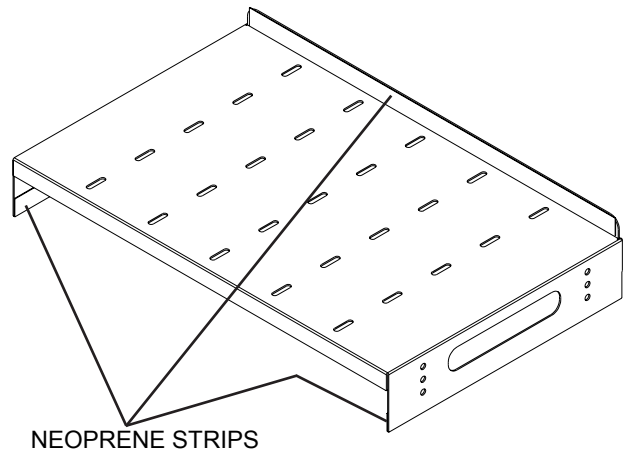

Figure 7.3b – Shelf

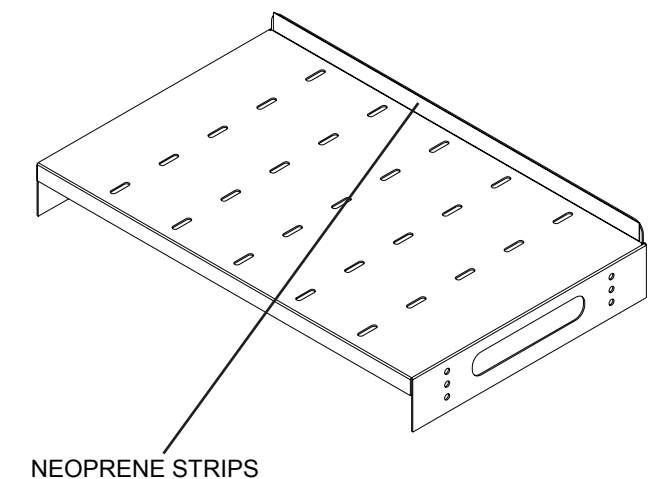

Figure 7.3c – Bottom Shelf

7.4 DATASAFE® 16HX UBC BATTERY RACK FRAME ASSEMBLY

This rack is best assembled with a minimum of 2 people. Refer to the rack assembly drawing in addition to this manual. A seismic, 5 Tier rack is shown.

- This rack has 4 corner frames to which the shelves, top and cross braces will be fastened to. See Figure 7.4a.
- Attach the bottom shelf to the 4 corner frames per Figure 7.4b. The 3-hole pattern in the bottom shelf is to have bolts in the upper and lower holes when fastening to each corner frame (middle hole is left empty). Finger tighten bolts.
- Attach the top cover to the 4 corner frames per Figure 7.4c. The 3-hole pattern in the top cover is to have bolts in the upper 2 holes when fastening to each corner frame (lower hole is left empty). Place bolts in each of the holes in the top and back of the top cover. Finger tighten bolts.

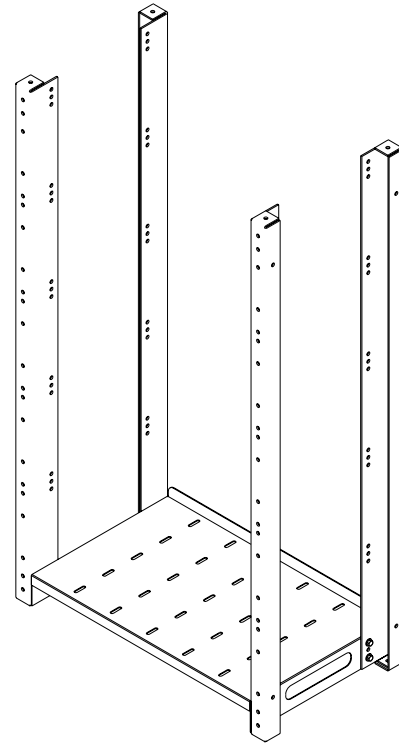

Figure 7.4b

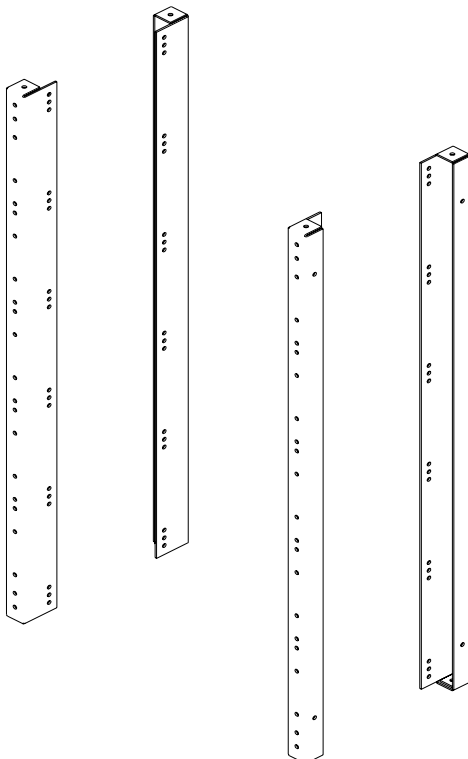

Figure 7.4a

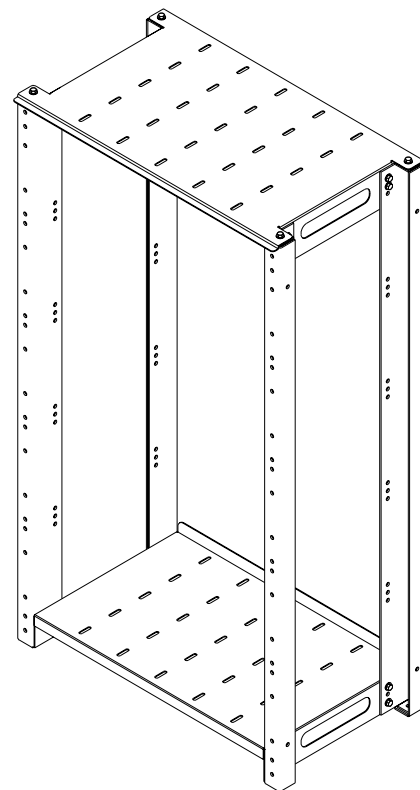

Figure 7.4c

7.5 DATASAFE® 16HX UBC BATTERY RACK SHELF ASSEMBLY

The bottom shelf was installed in section 7.4; install the remaining shelves beginning at the lower portion of the rack and work up. The quantity of shelves will be dependent on the rack style purchased. A 1 Tier rack will not have any shelves.

NOTE: It is recommended that batteries are not placed on the rack until all shelves are installed and all bolted connections are torqued per Table 1.

- Attach a shelf to the 4 corner frames per Figures 7.5a, 7.5b and 7.5c. The 3-hole pattern in the shelf is to have bolts in the upper 2 holes when fastening to each corner frame (lower hole is left empty). Finger tighten bolts.

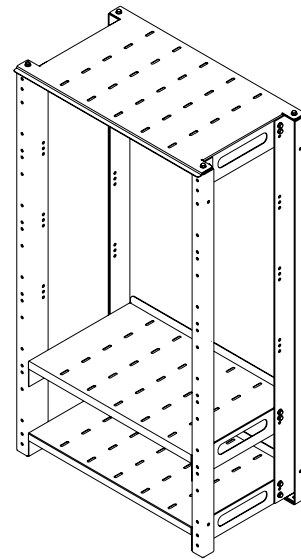

Figure 7.5a

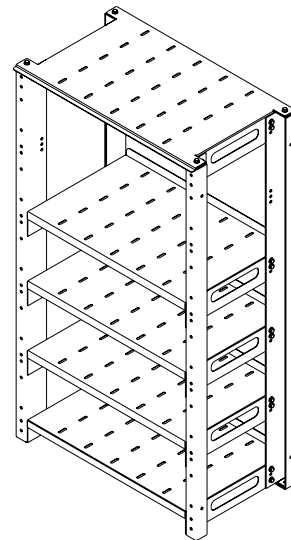

Figure 7.5b

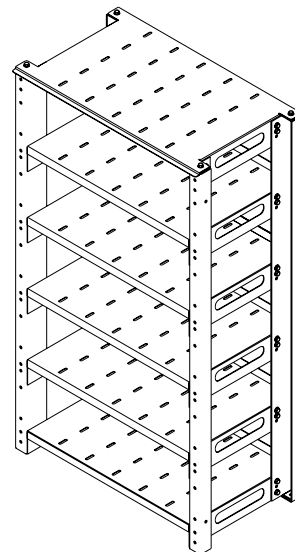

Figure 7.5c

7.6 DATASAFE® 16HX UBC BATTERY RACK CROSS BRACE ASSEMBLY

Non-seismic racks will only have rear cross braces, seismic racks will have rear and side cross braces.

- Install the rear cross braces per Figure 7.6a.
- For seismic racks, install the side cross braces per Figure 7.6b.
- Torque **ALL** connections per Table 1.

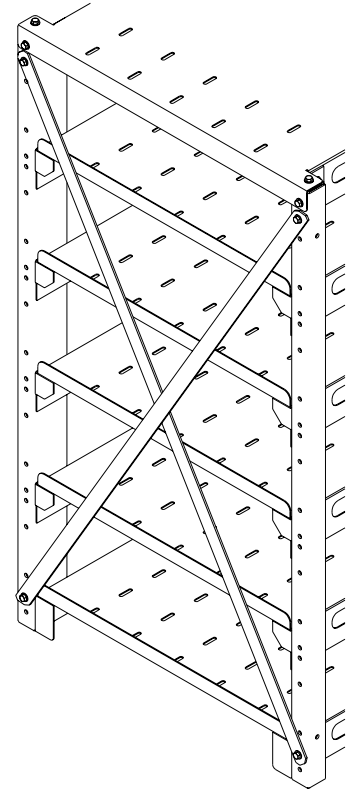

Figure 7.6a – Rear view of rack

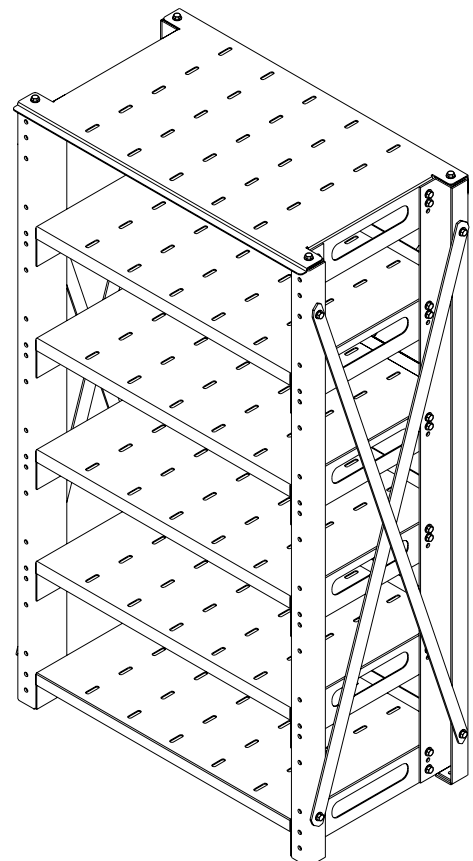

Figure 7.6b – Front view of rack

7.7 DATASAFE® 16HX UBC BATTERY RACK CELL INSTALLATION

Refer to DataSafe® HX battery *Installation, Operation and Maintenance Manual* for additional instructions.

NOTE: The bottom tier should contain the largest number of batteries when applicable.

- Make sure all bolts are torqued per Table 1 before installing batteries.
- Install batteries on shelves beginning on the bottom tier. Push each battery as far back on the shelf as possible.
- Battery bloc spacing is determined by the handle tab on each jar. This tab should be touching the tab on the adjacent battery bloc for proper fit of the cell to cell connectors.
- Each tier is designed to have a tight battery fit. There will approximately be a 1/8 in. (3 mm) gap between the batteries and rack when the tier is full.
- See Figures 7.7a, 7.7b and 7.7c.

CAUTION: Use appropriate lifting equipment to move the batteries to avoid injury.

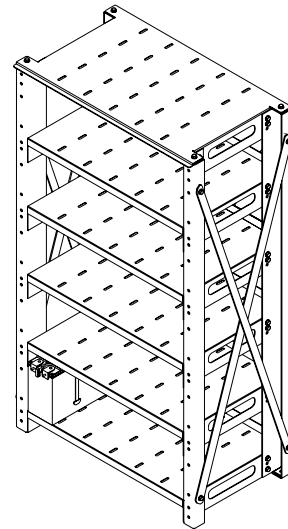

Figure 7.7a

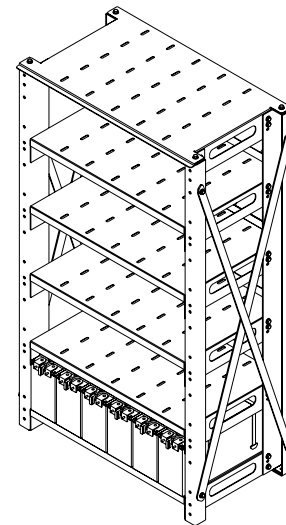

Figure 7.7b

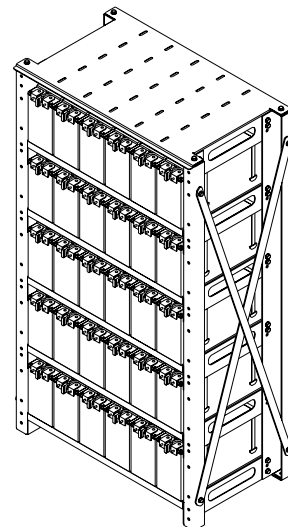

Figure 7.7c

7.8 DATASAFE® 16HX UBC BATTERY RACK SEISMIC RETAINERS

Retainers are required on all seismic racks.

- Install seismic retainers per Figure 7.8.
- Torque all connections per Table 1.

7.9 GROUNDING RACK (OPTIONAL)

Racks should be grounded when it is required for NEC and/or local codes.

- Remove/Scratch paint as necessary keeping the exposed metal to a minimum.
- Install lug and cable (lug and cable not furnished by EnerSys®.)
- Ohmmeter readings between each component and a common point on frame must indicate continuity to ensure proper grounding.

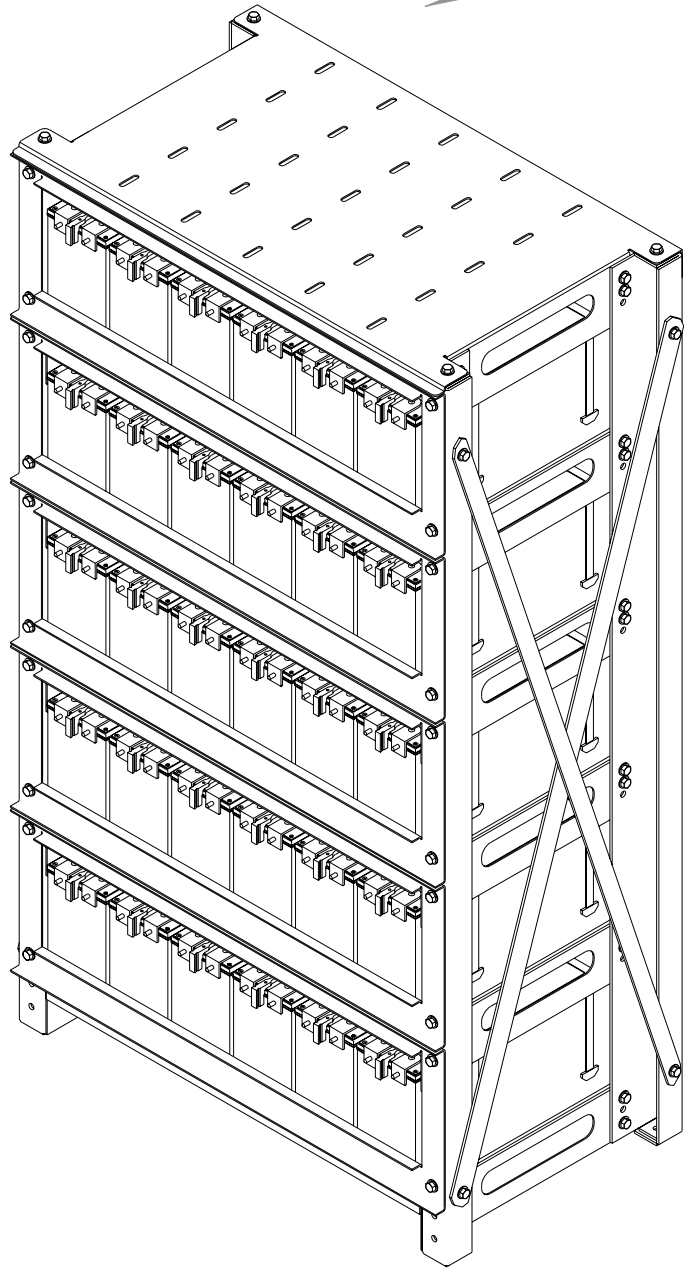

Figure 7.8

GLOSSARY OF TERMS

CONNECTORS	Electrical conductors used to connect adjacent cells on the same tier of a rack
CORNER FRAME	Vertical steel support structure of battery rack
CROSS BRACE	Steel brace used to connect rack frames together
EPA	U.S. Environmental Protection Agency
NEC	U.S. National Electric Code
NON-SEISMIC RACK	Rack designed to support the weight of the battery system only
NEOPRENE STRIPS	Self-Adhesive strips used to cushion the batteries on seismic racks (DataSafe® 16HX UBC Battery racks only)
OSHA	U.S. Occupational Safety & Health Administration
RESERVE POWER SERVICE	The EnerSys® service and installation group
SEISMIC RACK	Rack designed to withstand lateral loading in addition to the weight of the battery system
SHIMS	Thin metal spacers used to level rack due to uneven flooring
UBC	U.S. Uniform Building Code



EnerSys
P.O. Box 14145
Reading, PA 19612-4145
USA
Tel: +1-610-208-1991
+1-800-538-3627
Fax: +1-610-372-8613

EnerSys Europe
Zurich, Switzerland
Tel: +41 (0) 44 215 74 10

EnerSys Asia
Guangdong, China
Tel: +86-755-2689 3639

Distributed by:

© 2008 EnerSys. All rights reserved.
Trademarks and logos are the property of
EnerSys and its affiliates unless otherwise noted.